

Center Beam to Frac Sand Railcar Conversion

Alec Bolthouse, William Melcher, Riley Peterson, Nathaniel Scheetz, Becky Schlak, Jocelyn Tervo, Michigan Technological University

The demand for Center Beam railcars has been reduced a great deal with the decline of housing industry in recent years. Many of these cars are either lying idle or being sold for scrap value. Re-commissioning the cars for a different function with feasible modification would financially benefit the industry. Mechanical Engineering students at Michigan Tech have found that they can be converted into flat cars that could carry frac-sand for the growing Midwestern oil and natural gas industry.

Introduction

A center beam railcar is a flatcar with a large truss-like beam down the center of the car. The 'center-beam' provides the structural integrity of the railcar and allows for the loads up to 12 feet high. It is widely used to transport dimensional lumber needed in the construction industry. With reduced demand for the dimensional lumber center beams were designed to carry, many rail car owners are faced with an underutilized, outdated fleet of center beams with few options going forward. Many center beams are held in long term storage, or even sold for scrap value. In the interest of reducing long term cost and capital losses to railcar owners, the team was tasked to develop a proof of concept to convert center beams to another use with a realistic investment of time and resources. Students outlined steps required to convert a center beam railcar into a flatcar specifically tailored to carry seven pods of frac-sand for the growing Midwestern oil and natural gas industry. The conversion requires the removal of the center beam and modification of the center sill

underneath the deck to mitigate the structural strengths lost in the removal.



Figure 1. Model center beam car (right) and converted frac sand car with pods (left)

Design/Testing

Students used computer aided drafting and finite element analysis software to design a full scale flatcar with 14 Cross Beam members and an augmented center sill. Two W section beams welded to the center sill running the length of the car make up for load capacity lost when the center beam is removed. An unmodified center beam railcar has an average light weight of 62,400 lb, and a converted flatcar weighs roughly 10,000 pounds more without bulkheads. The proposed modification can support over 2 million pounds of compressive load before buckling, well exceeding AAR regulations. A 3D representation of one end of the car's modified center sill and of the complete sill are shown (in Figure 2a and 2b, respectively). The sill was manufactured in 1/4 scale and tested in a laboratory for bending (Figure 3).

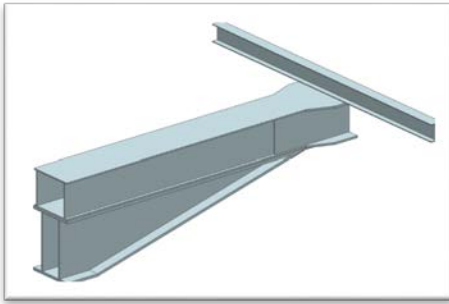

Figure 2(a). representation of one end of center still 3D



Figure 3. 1/4 scale prototype testing

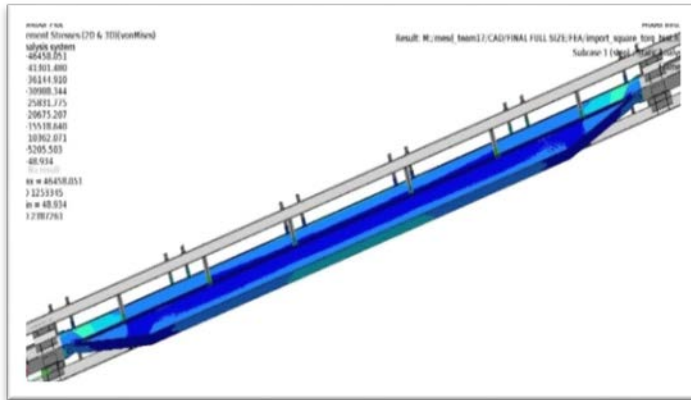

Figure 2(b). 3D representation of complete center still.

Cost

The cost of a frac sand conversion is estimated at \$16,793.98 (Figure 4). This number can be compared to the cost of a new flatcar, a minimum of \$80,000. A significant portion of the frac sand conversion cost is associated with 28 specially manufactured pod anchors, therefore it stands to reason that converting a car to a different use, perhaps to carry logs, may have equal or lesser cost, making conversion of center beam cars an attractive alternative to both long term storage *and* new car purchase.

Process	Component	Length Needed (ft)	Weight per Length (lb/ft)	Material Weight (lb)	Material Cost, Negative for Scrap (\$)	Shop Hours to Complete (hrs)	Shop Rate (\$/ hr)	Labor Cost (\$)	Total (\$)
Materials Added	W Section Beam (Fishbelly)	140	93	13,020	1529.85	25	55	1,375	2,904.85
	Pod Support Beams	140	12	1,680	197.40	30	55	1,650	1,847.40
	Brake Components Repositioning	-	-	-	2200.00	27	55	1,485	3,685.00
	Pod Anchor	-	-	-	6440.00	15	55	825	7,265.00
Materials Removed	Center Beam	73	140	10,200	-1198.50	17	55	935	-263.50
	Bulkhead (2)	-	-	3,800	-446.50	5	55	275	-171.50
								Total (\$)	15,267.25
								10% Contingency	1,526.73
								Net Cost (\$)	16,793.98

Figure 4: Estimated unit cost